

Overview and Identification

The Immersion Sensor with BAPI-Box Crossover enclosure is made for thermowell mounting and temperature measurement in water pipes, water tanks or cooling tower sump applications. The probe is made of Stainless Steel or Brass and comes in three lengths. The unit is available with multiple thermistor's or RTD's as shown in the specifications.

The BAPI-Box Crossover enclosure has a hinged cover for easy termination and comes with an IP10 rating (or IP44 rating with a pierceable knockout plug installed in the open port).

This instruction sheet is specific to units with the BAPI-Box Crossover Enclosure. For other enclosures, please refer to instruction sheet "20907_ins_Immersion_Passive.pdf" which is available on the BAPI website or by contacting BAPI.

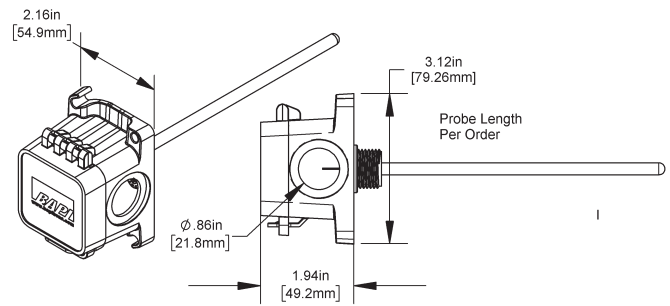

Fig. 1: BAPI-Box Crossover Immersion
(A Pierceable Knockout Plug is available from BAPI for the open port in the BAPI-Box Crossover enclosure.)

Thermowells and Immersion Sensors

Immersion Unit Probes are designed to be inserted into a Thermowell. Standard Thermowells from BAPI include machined 304 and 316 stainless steel and brass, and two-part welded 304 stainless steel. The Thermowell chosen for an installation is governed mainly by the corrosion conditions the well will face. Occasionally, the material consideration is one of strength rather than corrosion. For example, a machined stainless steel well may be required for high pressure water service where otherwise a brass or two-part stainless steel well would be satisfactory from a corrosion standpoint. The two-part welded stainless steel thermowells are not intended for service in moving water. Do not mount the two-part thermowells close to the inlet or outlet pipe of the tank.

Fig 4 on page 1 shows a typical four-inch thermowell and four-inch immersion probe installed into an eight-inch pipe.

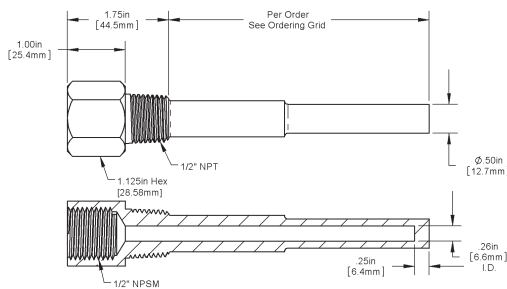

Fig. 2: Machined Thermowell

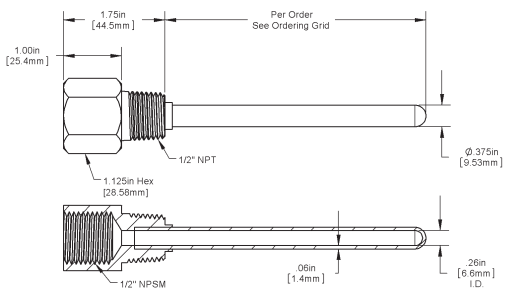

Fig. 3: Two-Part Welded Thermowell

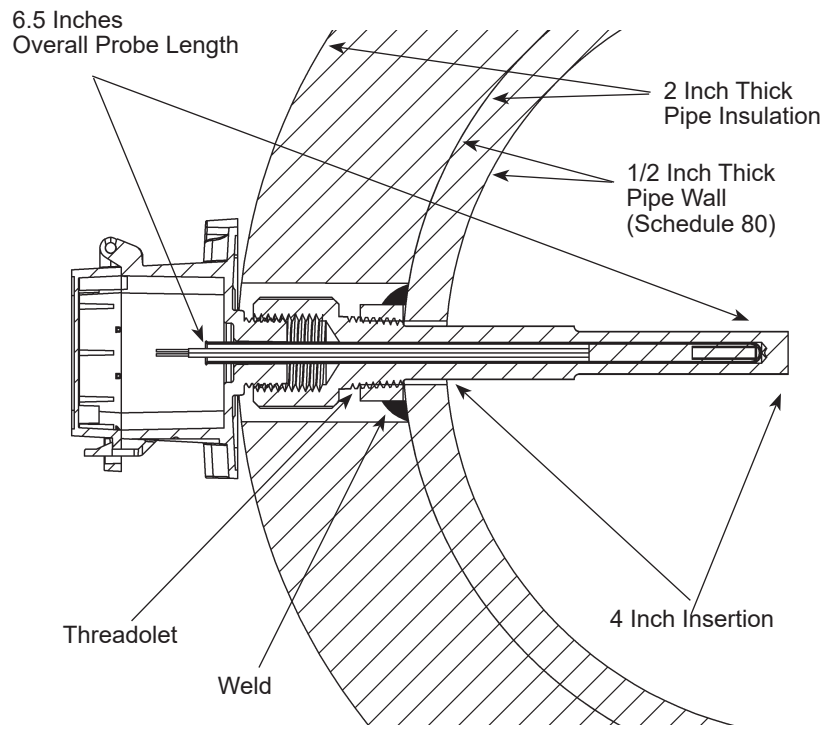

Fig. 4: Typical Sensor and Thermowell Installation

Specifications subject to change without notice.

Immersion Sensor Installation

Immersion probes come with a plastic fitting that screws into the threads at the top of the thermowell. Pull the probe away from the plastic fitting until the probe is fully extended. Insert the immersion probe into the thermowell until the plastic fittings come into contact with the threads in the thermowell. Hand tighten the immersion sensor snugly into the thermowell without too much torque. The unit is designed so that the temperature probe slides back into the enclosure as the sensor contacts the bottom of the thermowell. Make sure that the tip of the immersion sensor probe is in good contact with the bottom of the thermowell by pushing on the flared end of the probe until the tip bottoms out in the thermowell.

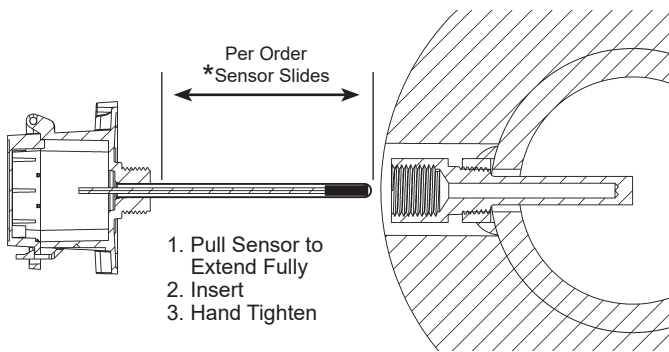

Fig. 5: BAPI-Box Crossover Unit Before Insertion

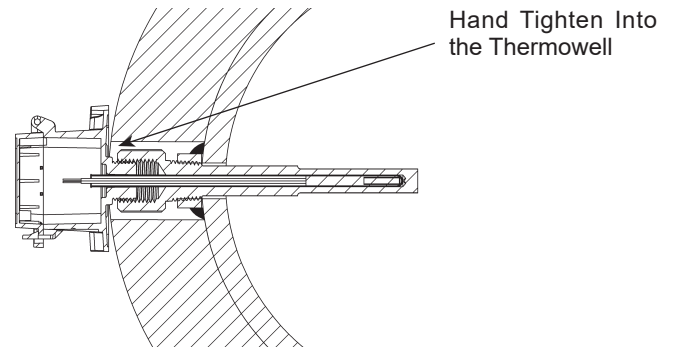

Fig. 6: BAPI-Box Crossover Unit Inserted

Note on Figs 5 & 6: As the immersion sensor is hand threaded into the thermowell, the flair end of the probe will be pushed back into the enclosure as the probe tip bottoms out in the thermowell. The probe can slide up to 1.6".

Installation in Pipes Less than 3" in Diameter

T-Mount

Figure 7 shows how a 2" Tee and a 1/2" to 2" bushing allows a 2" thermowell to measure the temperature of the contents of a 2" water pipe. Be sure to use a thread sealant on the outside threads of the thermowell.

Corner Mount

Figure 8 shows how a pipe Tee can be used in an elbow application. A 2" tee and a 1/2" to 2" bushing allows a 4" thermowell to measure the temperature of the contents of a 2" water pipe.

Note: Temperatures in pipes as small as 1-1/4" may be measured by this method. In small pipes, the diameter of the thermowell may become a significant obstruction, so be sure to check for proper flow rates after installation is complete.

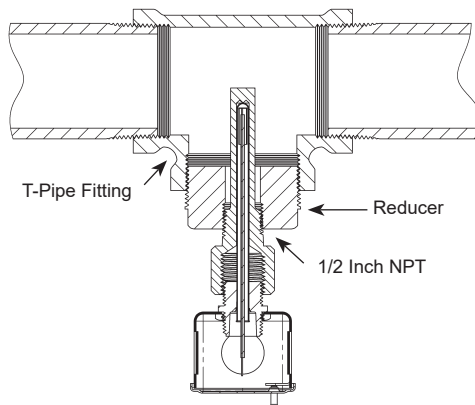

Fig. 7: Typical T-Mount
(shown with Junction Box enclosure)

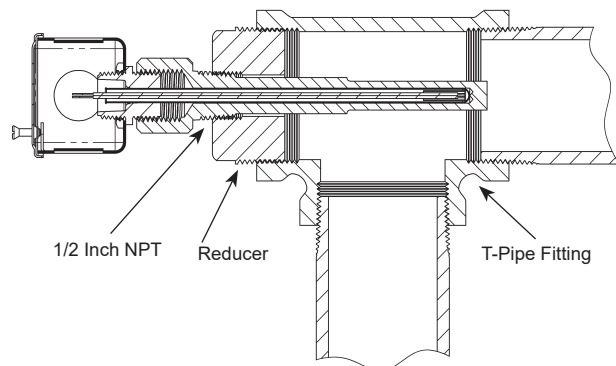

Fig. 8: Typical Corner Mount
(shown with Junction Box enclosure)

Specifications subject to change without notice.

Wiring & Termination

BAPI recommends using twisted pair of at least 22AWG and sealant filled connectors for all wire connections. Larger gauge wire may be required for long runs. All wiring must comply with the National Electric Code (NEC) and local codes. Do NOT run this device's wiring in the same conduit as high or low voltage AC power wiring. BAPI's tests show that inaccurate signal levels are possible when AC power wiring is present in the same conduit as the sensor wires.

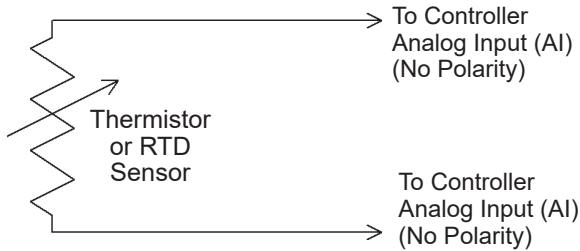

Fig. 9: 2-Wire Termination for Thermistor or RTDs

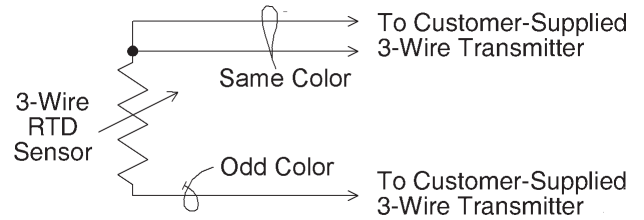

Fig. 10: 3-Wire Termination for RTDs

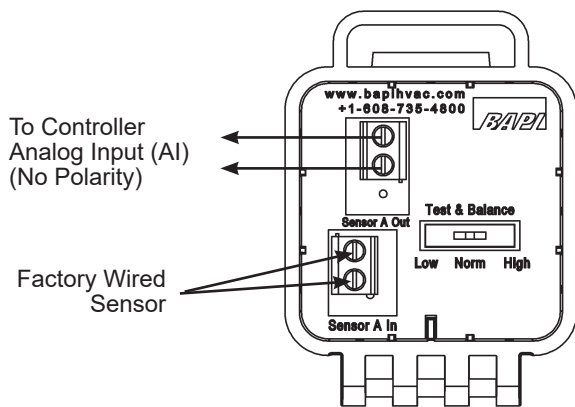

Fig. 11: Terminal Strip (-TS) or Test and Balance (TB) Option for 2 Wire Sensors

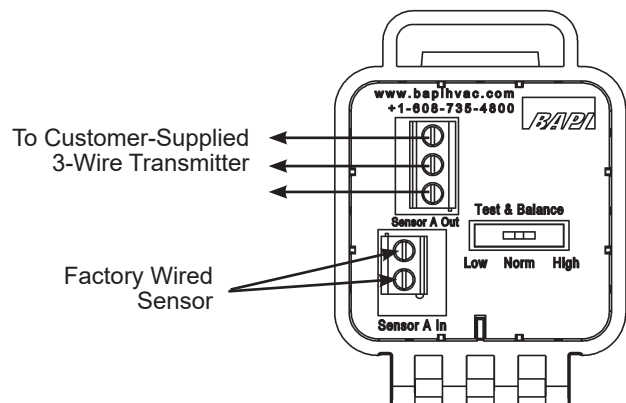

Fig. 12: Terminal Strip (-TS) or Test and Balance (TB) Option for 3 Wire Sensors

Test and Balance Switch:

For units with a Test and Balance Switch, the Norm position allows the real sensor at be monitored at "Sensor A Out". The High position forces the "Sensor A Out" to a very hot reading and the Low position forces "Sensor A Out" to a very cold reading (see Table below).

Sensor Type	Low Temp (40° F) Resistance Value	High Temp (105°F) Resistance Value
1000Ω RTD	1.02KΩ (41.20°F)	1.15KΩ (101.5°F)
3000Ω Thermistor	7.87KΩ (39.8°F)	1.5KΩ (106.8°F)
10K-2 Thermistor	30.1KΩ (34.9°F)	4.75Ω (109.1°F)
10K-3 Thermistor	26.7KΩ (35.9°F)	5.11KΩ (108.4°F)
10K-3(11K) Thermistor	7.32KΩ (43.7°F)	3.65Ω (105.2°F)

Specifications subject to change without notice.



Diagnosics

Possible Problems:

Controller reports higher or lower than actual temperature

Possible Solutions:

- Confirm the input is set up correctly in the front end software
- Check wiring for proper termination & continuity. (shorted or open)
- If the unit has a Test and Balance switch, make sure that the switch is in the center "Norm" position.
- Measure the physical temperature at the temperature sensor's location using an accurate temperature standard. Disconnect the temperature sensor wires and measure the temperature sensor's resistance across the sensor output pins with an ohmmeter. Compare the temperature sensor's resistance to the appropriate temperature sensor table on the BAPI website. If the measured resistance is different from the temperature table by more than 5% call BAPI technical support. Find BAPI's website at www.bapihvac.com; click on "Resource Library" and "Sensor Specs" then click on the type of sensor you have.

Specifications

SENSOR SPECS

Sensor: Passive

- Thermistor NTC, 2 wire
- RTD PTC, 2 or 3 wire

Thermistor: Thermal resistor

- Temp. Output..... Resistance
- Accuracy (Std) $\pm 0.36^{\circ}\text{F}$, ($\pm 0.2^{\circ}\text{C}$)
- Accuracy (High) $\pm 0.18^{\circ}\text{F}$, ($\pm 0.1^{\circ}\text{C}$), [XP] option
- Stability $< 0.036^{\circ}\text{F}/\text{Year}$, ($< 0.02^{\circ}\text{C}/\text{Year}$)
- Heat Dissipation $2.7 \text{ mW}/^{\circ}\text{C}$
- Temp. Drift..... $< 0.02^{\circ}\text{C}$ per year
- Probe Range -40° to 221°F (-40° to 105°C)

RTD: Resistance Temperature Device

- Platinum (Pt) 100Ω or $1\text{K}\Omega$ @ 0°C , 385 curve,
- Platinum (Pt) $1\text{K}\Omega$ @ 0°C , 375 curve
- Pt Accuracy (Std) ... 0.12% @Ref, or $\pm 0.55^{\circ}\text{F}$, ($\pm 0.3^{\circ}\text{C}$)
- Pt Accuracy (High) . 0.06% @Ref, or $\pm 0.277^{\circ}\text{F}$ ($\pm 0.15^{\circ}\text{C}$), [A]option
- Pt Stability $\pm 0.25^{\circ}\text{F}$, ($\pm 0.14^{\circ}\text{C}$)
- Pt Self Heating $0.4^{\circ}\text{C}/\text{mW}$ @ 0°C
- Pt Probe Range -40° to 221°F , (-40 to 105°C)
- Nickel (Ni) 1000Ω @ 70°F , JCI curve
- Ni Probe range -40° to 221°F (-40 to 105°C)

Sensitivity: Approximate @ 32°F (0°C)

- Thermistor Non-linear
See bapihvac.com "Sensor Specs"
- $1\text{K}\Omega$ RTD (Pt) $3.85\Omega/^{\circ}\text{C}$
- 100Ω RTD $0.385\Omega/^{\circ}\text{C}$
- Nickel (Ni) $2.95\Omega/^{\circ}\text{F}$ for the JCI RTD

ENCLOSURE AND WIRING SPECS

BAPI-Box Crossover Enclosure Ratings:

- IP10, NEMA 1
- IP44 with knockout plug installed in the open port

BAPI-Box Crossover Enclosure Material:

UV-resistant polycarbonate & Nylon, UL94V-0

Environmental Operating Range:

- -40 to 185°F (-40 to 85°C)
- 0 to 100% RH, Non-condensing

Lead Wire:

22AWG stranded

Wire Insulation:

Etched Teflon, Plenum rated

Probe:

304 or 316 Stainless Steel or Brass, 0.25" OD

Probe Length:

2", 4", 8"

Agency:

RoHS
PT= DIN43760, IEC Pub 751-1983,
JIS C1604-1989

Specifications subject to change without notice.