

Overview and Identification

The Rigid Averaging Unit is for duct mounting and temperature measurement of stratified air across the duct to give the average temperature along the length of the sensor. They can be ordered with a variety of thermistor or RTD sensors.

The BAPI-Box Crossover enclosure has a hinged cover for easy termination and comes with an IP10 rating (or IP44 rating with a pierceable knockout plug installed in the open port).

This instruction sheet is specific to units with the BAPI-Box Crossover Enclosure. For other enclosures, please refer to instruction sheet "20904_ins_DuctAvgRigid_Passive.pdf" which is available on the BAPI website or by contacting BAPI.

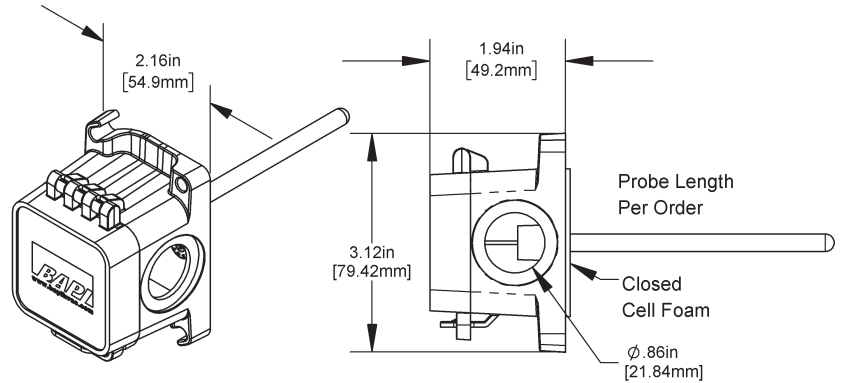

Fig. 1: Rigid Averaging Unit with BAPI-Box Crossover Enclosure

Mounting

1. Place the sensor in the middle of the duct away from temperature stratified air, coils or humidifiers to achieve the best temperature reading.
2. Drill the probe hole as shown in Fig. 2. Insert the probe into the duct.
3. Mount the enclosure to the duct using BAPI recommended #8 screws through a minimum of two opposing mounting tabs. A 1/8 inch pilot screw hole in the duct makes mounting easier through the mounting tabs. Use the enclosure tabs to mark the pilot hole locations.
4. Snug up the sensor so that the foam backing is depressed to prevent air leakage but do not over-tighten or strip the screw threads.
5. A pierceable knockout plug is available for the open port in the BAPI-Box Crossover enclosure (see Fig. 4). The plug increases the enclosure rating from IP10 to IP44.

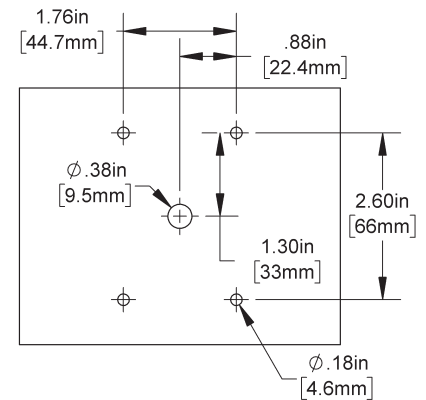

Fig. 2: BAPI-Box Crossover Enclosure Mounting Holes

Notes:

Use caulk or Teflon tape for your conduit entries to maintain the appropriate IP or NEMA rating for your application.

Conduit entry for outdoor or wet applications should be from the bottom of the enclosure.

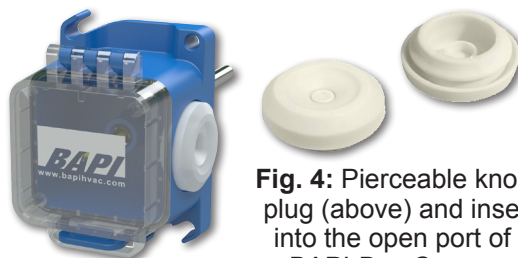

Fig. 4: Pierceable knockout plug (above) and inserted into the open port of the BAPI-Box Crossover.

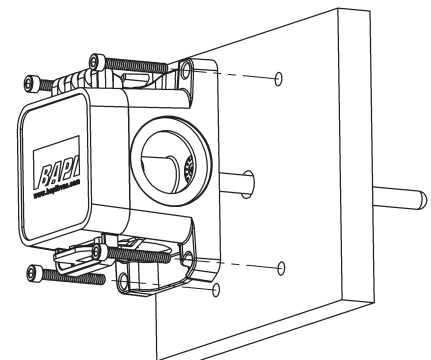

Fig. 3: BAPI-Box Crossover Mounting to the Duct

Specifications subject to change without notice.

Wiring & Termination

BAPI recommends using twisted pair of at least 22AWG and sealant filled connectors for all wire connections. Larger gauge wire may be required for long runs. All wiring must comply with the National Electric Code (NEC) and local codes. Do NOT run this device's wiring in the same conduit as high or low voltage AC power wiring. BAPI's tests show that inaccurate signal levels are possible when AC power wiring is present in the same conduit as the sensor wires.

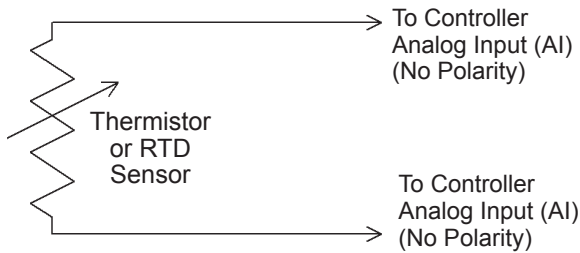

Fig. 5: 2-Wire Termination for Thermistor or RTDs

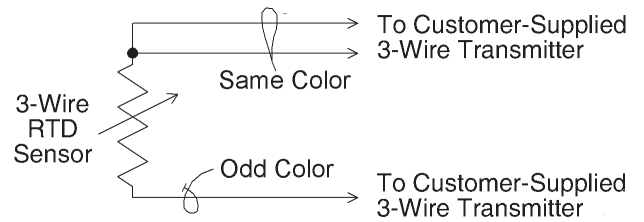

Fig. 6: 3-Wire Termination for RTDs

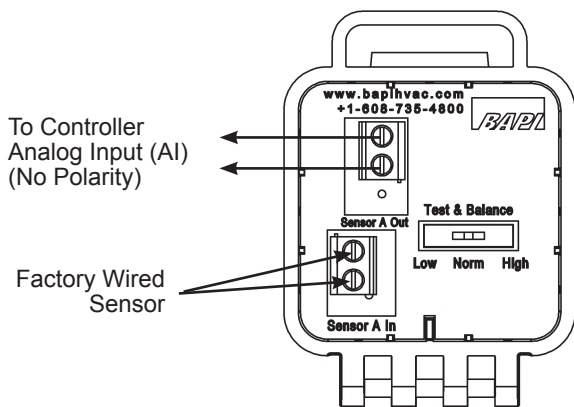

Fig. 7: Terminal Strip (-TS) or Test and Balance (TB) Option for 2 Wire Sensors

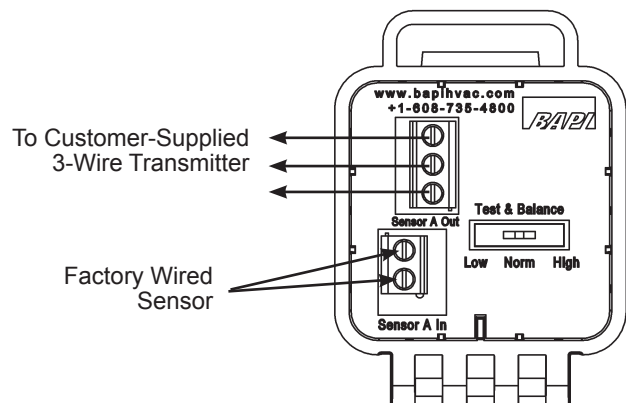

Fig. 8: Terminal Strip (-TS) or Test and Balance (TB) Option for 3 Wire Sensors

Test and Balance Switch:

For units with a Test and Balance Switch, the Norm position allows the real sensor at be monitored at "Sensor A Out". The High position forces the "Sensor A Out" to a very hot reading and the Low position forces "Sensor A Out" to a very cold reading (see Table below).

Sensor Type	Low Temp (40° F) Resistance Value	High Temp (105°F) Resistance Value
1000Ω RTD	1.02KΩ (41.20°F)	1.15KΩ (101.5°F)
3000Ω Thermistor	7.87KΩ (39.8°F)	1.5KΩ (106.8°F)
10K-2 Thermistor	30.1KΩ (34.9°F)	4.75Ω (109.1°F)
10K-3 Thermistor	26.7KΩ (35.9°F)	5.11KΩ (108.4°F)
10K-3(11K) Thermistor	7.32KΩ (43.7°F)	3.65Ω (105.2°F)

Specifications subject to change without notice.



Diagnosics

Possible Problems:

Controller reports higher or lower than actual temperature

Possible Solutions:

- Confirm the input is set up correctly in the front end software
- Check wiring for proper termination & continuity. (shorted or open)
- If the unit has a Test and Balance switch, make sure that the switch is in the center "Norm" position.
- Measure the physical temperature at the temperature sensor's location using an accurate temperature standard. Disconnect the temperature sensor wires and measure the temperature sensor's resistance across the sensor output pins with an ohmmeter. Compare the temperature sensor's resistance to the appropriate temperature sensor table on the BAPI website. If the measured resistance is different from the temperature table by more than 5% call BAPI technical support. Find BAPI's website at www.bapihvac.com; click on "Resource Library" and "Sensor Specs" then click on the type of sensor you have.

Specifications

SENSOR SPECS

Sensor: Passive

- Thermistor NTC, 2 wire
- RTD PTC, 2 or 3 wire

Thermistor: Thermal resistor

- Temp. Output..... Resistance
- Accuracy (Std) $\pm 0.36^{\circ}\text{F}$, ($\pm 0.2^{\circ}\text{C}$)
- Accuracy (High) $\pm 0.18^{\circ}\text{F}$, ($\pm 0.1^{\circ}\text{C}$), [XP] option
- Stability $< 0.036^{\circ}\text{F}/\text{Year}$, ($< 0.02^{\circ}\text{C}/\text{Year}$)
- Heat Dissipation $2.7 \text{ mW}/^{\circ}\text{C}$
- Temp. Drift..... $< 0.02^{\circ}\text{C}$ per year
- Probe Range -40° to 221°F (-40° to 105°C)

RTD: Resistance Temperature Device

- Platinum (Pt) 100Ω or $1\text{K}\Omega$ @ 0°C , 385 curve,
- Platinum (Pt) $1\text{K}\Omega$ @ 0°C , 375 curve
- Pt Accuracy (Std) ... 0.12% @Ref, or $\pm 0.55^{\circ}\text{F}$, ($\pm 0.3^{\circ}\text{C}$)
- Pt Accuracy (High) . 0.06% @Ref, or $\pm 0.277^{\circ}\text{F}$ ($\pm 0.15^{\circ}\text{C}$), [A]option
- Pt Stability $\pm 0.25^{\circ}\text{F}$, ($\pm 0.14^{\circ}\text{C}$)
- Pt Self Heating $0.4^{\circ}\text{C}/\text{mW}$ @ 0°C
- Pt Probe Range -40° to 221°F , (-40 to 105°C)
- Nickel (Ni) 1000Ω @ 70°F , JCI curve
- Ni Probe range -40° to 221°F (-40 to 105°C)

Sensitivity: Approximate @ 32°F (0°C)

- Thermistor Non-linear
See bapihvac.com "Sensor Specs"
- $1\text{K}\Omega$ RTD (Pt) $3.85\Omega/^{\circ}\text{C}$
- 100Ω RTD $0.385\Omega/^{\circ}\text{C}$
- Nickel (Ni) $2.95\Omega/^{\circ}\text{F}$ for the JCI RTD

ENCLOSURE AND WIRING SPECS

BAPI-Box Crossover Enclosure Ratings:

- IP10, NEMA 1
- IP44 with knockout plug installed in the open port

BAPI-Box Crossover Enclosure Material:

- UV-resistant polycarbonate & Nylon, UL94V-0

Environmental Operating Range:

- -40 to 185°F (-40 to 85°C)
- 0 to 100% RH, Non-condensing

Lead Wire:

- 22AWG stranded

Wire Insulation:

- Etched Teflon, Plenum rated

Probe:

- Rigid Stainless Steel, 0.25" OD

Probe Length:

- 12", 2' or 4' per order

Duct Gasket:

- 1/4" Closed cell foam (impervious to mold)

Agency:

- RoHS
- PT= DIN43760, IEC Pub 751-1983,
- JIS C1604-1989

Specifications subject to change without notice.