

## Overview and Identification

The Adjustable Pressure Switch is designed for monitoring overpressure, vacuum and differential pressure of air or other non-combustible, non-aggressive gases.

A field-adjustable dial allows you to select any trip value within each pressure range. Tubing and two total tubes are available as an accessory.

Possible fields of application include:

- Monitoring air filters and fan status
- Monitoring industrial cooling-air circuits
- Monitoring flows in ventilation ducts
- Used as an air flow proving switch for heater control and frost prevention circuits

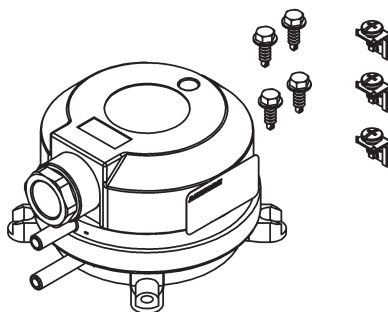

**Fig. 1:** Adjustable Differential Pressure Switch

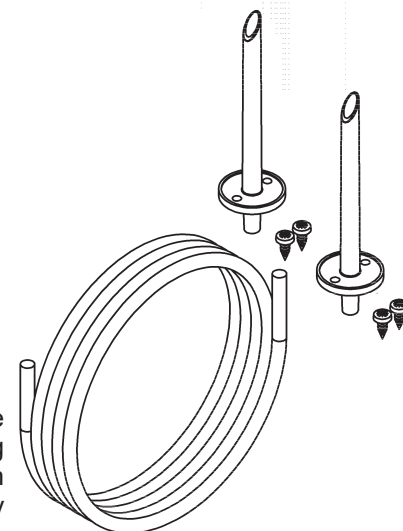

**Fig. 2:** Total Pressure Probes and Tubing available as an accessory

## Mounting

Hold the unit vertically (pressure connections pointing downward) in its mounting location and mark the holes in the mounting feet as shown in Fig. 3 at right. For a more accurate vertical placement, use a combination or "speed" square with a level to draw an "X" and locate the mounting holes on the lines. Do not mount the pressure switch on uneven surfaces which can cause the unit to warp and eventually fail.

Note: Only mount the unit horizontally (pressure connections pointing sideways) if no condensate can form. The unit is position sensitive, so when the unit is positioned horizontally, the switching values are approximately .08 WC (20 Pa) higher than indicated on the scale.

Mount the pressure switch with the pressure connections pointing downwards to drain condensation moisture which might occur. Mount the pressure switch above the pressure ports that are being monitored. This will allow condensation to drain to the pressure ports instead of being trapped in the tubing or forced into the pressure switch.

Using the included #8 screws, attach the unit to the mounting surface. Do not over tighten the screws, which can deform the device's base.

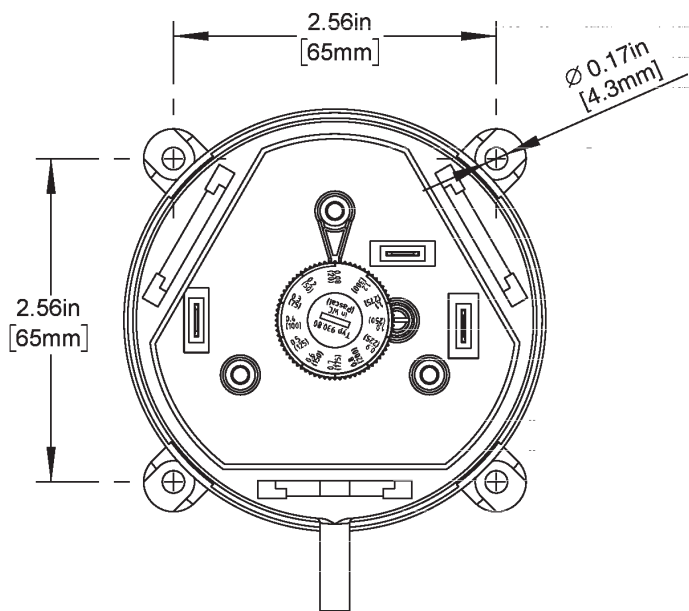

**Fig. 3:** Pressure Switch Mounting

## Tubing Connection

Install the pressure tubing on the "P1 +" (high) and "P2 -" (low) ports. Make sure that tubing is not bent or leaking after installation. Leaking tubing and connections will cause inaccurate measurements.

Specifications subject to change without notice.

## Pressure Switch Adjustment

Remove power from unit before making any adjustments to the pressure switch.

Remove the cover and use a screwdriver to set the desired trip pressure on the adjustment dial (Fig. 4)

Replace the cover (Fig. 5) and push on the cover until it latches. Secure the cover with the cover screw(s). Do not operate the system until the housing is closed. Check the trip and reset pressure by slowly increasing and decreasing pressure. Repeat the adjustment procedure if needed.

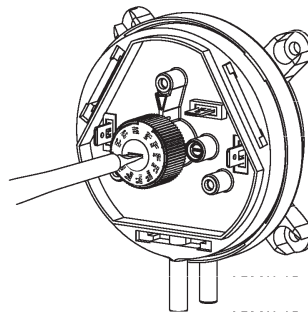

Fig. 4: Pressure Switch Adjustment Dial

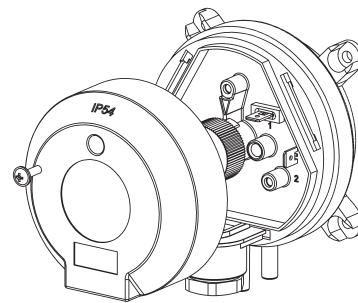

Fig. 5: Cover Replacement and Screw

Part #	Pressure Range	Encl. Rating
BA/APSW1	..0.08 to 1.2" WC / 20 to 300 Pa	.....IP54
BA/APSW2	...0.2 to 2" WC / 50 to 500 Pa	.....IP54
BA/APSW3	...0.8 to 4" WC / 200 to 1,000 Pa	.....IP54
BA/APSW4	...0.12 to 1.6" WC / 30 to 400 Pa	.....IP54
BA/APSW5	...2 to 10" WC / 500 to 2500 Pa	.....IP54
BA/APSW6	...4 to 20" WC / 1000 to 5000 Pa	.....IP54

Part #	Pressure Range	Encl. Rating
BA/APSW1-65	...0.08 to 1.2" WC / 20 to 300 Pa	.....IP65
BA/APSW2-65	...0.2 to 2" WC / 50 to 500 Pa	.....IP65
BA/APSW3-65	...0.8 to 4" WC / 200 to 1,000 Pa	.....IP65
BA/APSW4-65	...0.12 to 1.6" WC / 30 to 400 Pa	.....IP65
BA/APSW5-65	...2 to 10" WC / 500 to 2500 Pa	.....IP65
BA/APSW6-65	...4 to 20" WC / 1000 to 5000 Pa	.....IP65

BA/APSW-ACC...2 Total Pressure Probes and 2 Meters of Pressure Tubing

## Termination



BAPI recommends wiring the product with power disconnected. Proper supply voltage, polarity and wiring connections are important to a successful installation. Not observing these recommendations may damage the product and void the warranty.

Remove the cover from the unit. Use a three-conductor cable if normally open, normally closed, and common terminals will all be used in the application. Use a two-conductor cable if only two terminals will be used. The outer diameter of the cable must be from 1/4 and 3/8" (5 to 10mm). Run the cable through the liquid tight fitting (Fig. 6) and tighten fitting until the cable is secure.

Attach included spade terminals to the ends of the electrical wires (Fig. 7). Install the spade terminals on the three terminals inside the unit (Fig. 8). Standard 1/4" crimp-on spade connectors (not provided) may be used with stranded wire at installer's discretion.

The switch in the unit is a "Form C" type contact. Pole 3 (COM) closes to Pole 2 (NO) when the pressure is above the trip point. Pole 3 closes to Pole 1 (NC) when the pressure is below the trip point. See Specifications on pg 3 for switch electrical rating.

Replace the cover and push on the cover until it latches. Secure the cover with the cover screw.

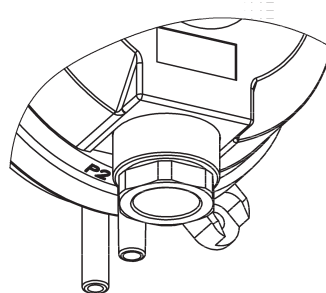

Fig. 6: Included Liquid Tight Fitting

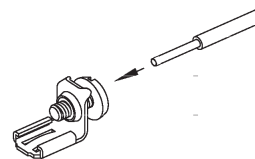

Fig. 7: Included Spade Connectors

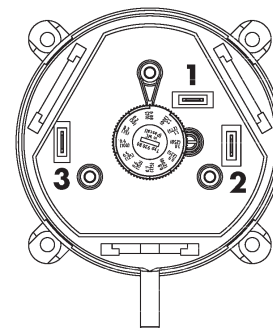

Fig. 8: Pressure Switch Contacts



Specifications subject to change without notice.

## Diagnosics

### Possible Problems:

Switch does not trip at correct pressure

### Possible Solutions:

- Make sure that the high and low pressure tubes are connected to the proper locations and are not kinked.
- Make sure that switch terminals are wired correctly as described in the "Termination" section on page 2.
- Make sure that the air mover is actually on.

## Specifications

**Burst Pressure:** 40" WC (10 kPa) for all pressure ranges

**Medium:** Air, non-combustible and non-aggressive gases

**Operating Temperature:** -4° to +185°F (-20 to +85°C)

**Storage Temperature:** -40°F to +185°F (-40 to +85°C)

### Accuracy:

Deviation:  $\leq \pm 15\%$ , min.  $\pm 0.04$ " WC ( $\pm 10$  Pa) • Drift:  $\leq \pm 15\%$

### Diaphragm Material:

Silicone, tempered at 392°F (200°C), free of gas emissions.

### Pressure Connections:

2 plastic pipe connection pieces, external dia. 0.24" (6mm)  
Marked "+" to higher pressure, marked "-" to lower pressure

**Body and Cover Material:** UV-resistant plastic

**Mechanical Working Life:** Over 1,000,000 switching operations.

### Electrical Rating:

0.4A Inductive, 250 VAC • 1.5A Resistive, 250 VAC

0.8A Inductive, 125 VAC • 3.0A Resistive, 125 VAC

0.4A, 30VDC • 0.1A, 24 VDC

### Electrical connections:

1/4" Spade Plug (AMP flat plug), 0.25" x 0.03" (6.3 x 0.8mm) in accordance with DIN 46244 or push-on screw terminals included.

**Protection Category:** IP54 or IP65

**Cable Conduit:** M20 threads for 0.25" to 0.375" OD cable (6.5 to 9.5mm)

### CE Conformity:

Low Voltage Directive 2014/35/EU; RoHS Directive 2011/65/EU

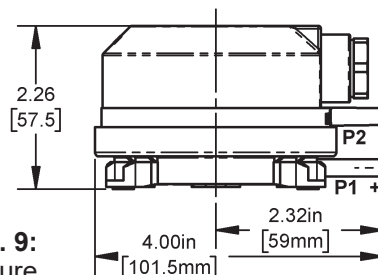

**Fig. 9:**  
Pressure  
Switch  
Dimensions

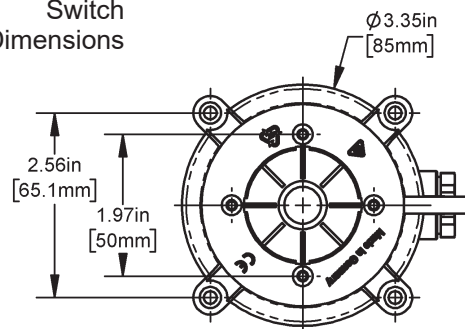

**Fig. 10:** Accessory  
Total Tube  
Dimensions

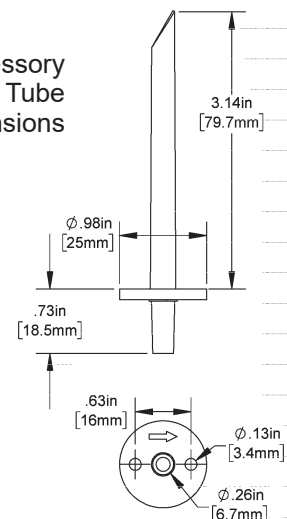

Specifications subject to change without notice.



# Adjustable Pressure Switch

Installation & Operating Instructions

42074\_ins\_APSW

rev. 01/31/25

## Applications

### AIR FILTER MONITORING

The static pressure on each side of a filter is compared and the output contacts close when the pressure across the filter exceeds a predetermined value. Install one pressure probe at least one duct diameter upstream of the filter and install another probe at least one duct diameter downstream of the filter. If using total pressure probes, make sure the open end of each probe is facing AWAY from the air flow in the duct. Connect the upstream probe to the high port on the Adjustable Pressure Switch and the down stream probe to the low port on the Adjustable Pressure Switch.

To set the pressure trip point, remove the tubing from the Adjustable Pressure Switch. Connect a manometer and a pressure source to the high pressure port on the Adjustable Pressure Switch. Use the manometer and the pressure source to set the desired trip pressure. Set the desired trip pressure as described in the "Pressure Switch Adjustment" section on page 2. Reconnect tubing when finished.

An alternative way to adjust the pressure setpoint is to place a new, clean filter into the duct then turn on the fan. Cut a piece of cardboard approximately 1/2 the face area of the filter and place the cardboard against the filter on the upstream side. Set the desired trip pressure as described in the "Pressure Switch Adjustment" section above. Remove the cardboard when finished.

### STATIC PRESSURE PROVING

Static pressure proving compares the static pressure in a monitored space to the static pressure in a reference space. The Pressure Switch contacts close when the pressure exceeds the setpoint. The Pressure Switch is independent of any static pressure control; it is an independent monitor and alarm if the control condition is not met.

For example, you do not wish the odors in a school chemistry laboratory to get out into the hallway. The lab is the monitored space and the hallway is the reference space. Place one pressure probe into the monitor space and place another into the reference space. If you want the reference space to be higher pressure, connect the reference space to the Pressure Switch high port and the monitored space to the low port. If you want the monitored space to be higher pressure, connect the monitored space to the high port and the reference space to the low port.

Connect a manometer and a pressure source to the high pressure port on the Pressure Switch. Use the manometer and the pressure source to set the desired trip pressure as described in the "Pressure Switch Adjustment" section on page 2. Reconnect the tubing when finished.

Another example is making sure that the static pressure in a duct is different from the static pressure in your plenum. The duct is the monitored space and the plenum is the reference space. Place one pressure probe into the duct. If it is a total probe, make sure the open end of the probe is facing AWAY from the air flow. Place another pressure probe in the plenum. Connect the sensor tubing and set the trip pressure as described in the previous two paragraphs.

### AIR FLOW PROVING

Place one total pressure probe into the duct you wish to monitor with the open end of the probe facing INTO the air flow. Connect this probe to the high port of the Pressure Switch. Place a static probe (or another total probe with the open end facing AWAY from the airflow) into the duct. Connect this probe to the low port of the Pressure Switch. Set the pressure trip point to the desired airflow.

Flow, Feet per Minute	Pressure, Inches of Water
1000	0.062
2000	0.25
3000	0.56
4000	1

### FAN STATUS

Place the low port probe on the entering air side of any fan and the high port probe on the leaving air side of the fan. This will give you positive fan status which will not give a false reading when the fan belt breaks or the local disconnect is open.

Specifications subject to change without notice.